

Potential of an electric brake resistor to increase the efficiency of electric vehicles

Johannes Lieb¹, Egor Sawazki², Martin Brüll², Bernard Bäker³

¹*BMW Group, München, Johannes.Lieb@bmw.de*

²*Continental, Regensburg*

³*Institute for Automotive Technology, Technische Universität Dresden, Dresden*

Abstract

Electric brake resistors are well known in the domain of power electronics, railway or elevator technology to guarantee electric braking or to damp high electric power peaks. The generated heat energy, however, is usually dissipated. This work deals with the potential of an automotive application of the electric brake resistor to enable brake energy regeneration (recuperation) also at low temperatures and high state of charge when the charge performance of the traction battery is limited. By reusing the excess recuperation energy to support the vehicle's cabin heating, the overall energy efficiency can be increased. In this paper three classes of battery electric vehicles are simulated with different driving environments and start parameters to assess the influences on the efficiency potential of this application. It is shown that, depending on the start conditions and drive cycle, the total energy demand can be reduced by up to 12% with the use of a 6kW rated brake resistor.

Keywords: battery electric vehicle, brake energy regeneration, brake resistor, thermal recuperation

1 Introduction

The architects of electric vehicles have to deal with the limited capacity of today's Lithium-ion batteries [1]. Beside the optimization of the motion resistances e.g. via weight reduction, brake energy regeneration (recuperation) plays a much more important role for electrical vehicles to ensure a certain range with this limited battery capacity. Unfortunately, the recuperation capability is dependent on the charge power limit of the battery, which varies over temperature, state of charge and age, as previous work has shown [2]. Additionally, the driving range of electric vehicles is affected by the considerable amount of electric energy needed for climate control. At low temperatures the excess recuperation energy could be used to heat the passenger compartment

directly, but common heating systems only allow constant power operation with limited power. The introduction of an electric brake resistor could enable this synergy, thus mitigating the impact of low temperatures on the electric driving range.

The most important feature of the brake resistor in this context is its distinct overload capability. Depending on the internal structure it can be designed to exceed its rated power by multiple times to handle the high power peaks associated with regenerative braking. Since modern, water cooled brake resistors are smaller and lighter than the ones known from industrial application, they have become most interesting for automotive application, especially for compact electric vehicles.

The classical industrial use cases are recurring events like the deceleration of an elevator. The generated heat involved with the braking opera-

tion, is usually dissipated. The challenge for an automotive application is the human based unpredictable driving situation and the varying demand for heating power.

As part of the research project EFA2014/2 (“Energy Efficient Driving 2014 – phase 2”), [3] funded by the German government, a water cooled and minimized brake resistor is integrated into an electric vehicle. The main goal is to reuse the excess brake energy to directly contribute heat flow to the vehicle’s climate control system. As a further benefit of this application, it has the capability to reduce complexity and wear in the conventional brake system, if recuperation can be guaranteed, independent of the battery condition. In this work the recuperation power from several standard driving cycles is analyzed for different vehicle categories. Design criteria for the brake resistor component are derived and the efficiency potential at varying start conditions is presented.

2 Research method

The efficiency potential is studied by means of parameter variations in a dynamic vehicle simulation. A component model of an electric brake resistor is integrated in a simulation environment developed in previous work (cf. [2], [4]).

2.1 Brake resistor design

2.1.1 Basic principle

Figure 1 shows the functional prototype of a brake resistor provided by REO inductive components AG including a cross-sectional view of its internal structure.

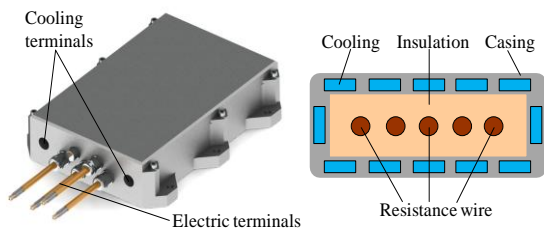

Figure 1: Electric brake resistor prototype and cross-sectional view

As current flows through the resistance wire elements the generated heat is conducted through the electrical insulation material and the aluminum casing into the cooling tubes. The combination of heat capacity and conductance parameters determines the component’s overload capability. In a first design step an energetic approach can be used to assess the resistor’s time-dependent

performance. It states that the rated power of the component can be exceeded as long as the energy throughput within a defined time frame is limited to the rated value. This approach results in two main design parameters for the component:

1. The rated power for continuous operation $P_{cont.}$. It is defined as the electrical power that can be dissipated in a steady state so that the wire temperature does not exceed a certain safety threshold, e.g. 800 °C.
2. The time constant τ , setting the width of the reference time frame. It determines the component’s thermal inertia, defining how fast the wire temperature reaches a steady state upon constant power, e.g. 120 s.

Equation (1) gives the basic relation between peak and continuous power for constant power pulses.

$$P_{peak} = P_{cont.} \cdot \frac{\tau}{t_{on}} \quad (1)$$

As an example, a resistor designed with a continuous power rating of 5 kW and a time constant of 120 s could also be operated with 50 kW pulses lasting for only 12 s. For dynamic operation like automotive applications an integral version of this equation has to be applied, but the basic principle remains the same.

2.1.2 Brake resistor component model

To simulate the component’s thermal behavior a one dimensional equivalent circuit model is used. Figure 2 shows the layout of the developed model consisting of effective heat conductance (G_x) and capacity (C_x) elements. It is implemented in the Modelica® language and parameterized using component measurements of the prototype depicted in Figure 1.

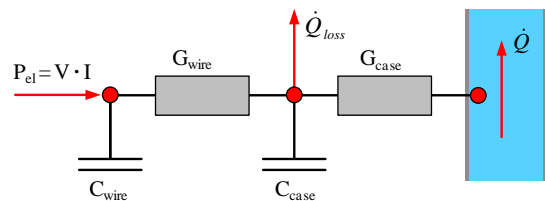

Figure 2: Electric brake resistor simulation model

The loss Heat \dot{Q}_{loss} is caused by the radiation and convection of heat over the surface of the casing. For the evaluation in this paper it is assumed that the loss heat is in the order of a conventional water heater. Note that there are no separate elements for the insulation material as its contribution is partly included in the parameters of the wire and the case. As Figure 3 indicates the temperature of the resistance wire and the coolant can be sufficiently

fitted using only the four selected elements. For further validation step responses, power pulses and drive cycle measurements are used.

2.1.3 Parameterization approach

The following chapter describes how the model parameters are derived from the power requirements to the component. The presented approach is used in the course of this work to create various classes of braking resistors with different behavior. The model parameters are obtained in an iterative process, starting from a reference model data set:

1. Set the coolant parameters according to the application (e.g. 16 l/min, $T_{in}=20^{\circ}\text{C}$).
2. As depicted in Figure 4A, adjust the heat conductance G_{wire} so the wire temperature does not exceed the allowable limit upon a power step of P_{cont} .
3. Adapt the heat capacity C_{wire} to set the desired time constant τ , see Figure 4B.
4. Adjust G_{case} and C_{case} simultaneously to select the desired dynamic in coolant temperature upon power step and pulse excitation, see Figure 4C and 4D.
5. Repeat step 2-4 for fine tuning.

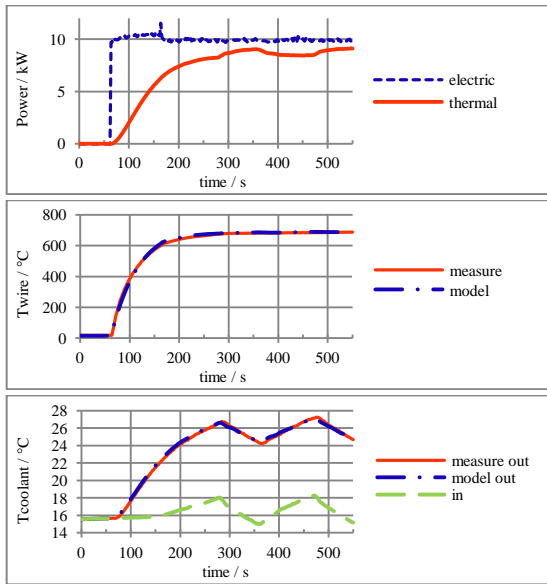

Figure 3: Model verification based on component measurements

For this approach the right order is essential. Parameter studies have shown that parameters related to the case have little impact on the wire temperature which is why the wire parameters are to be set first. In reality the various parameters are not fully independent. But there are many technological levers to adjust them individually

within a certain margin. Changing the thermal capacity by applying more thermal mass, for example, also has an influence on the heat conductivity properties. This impact, however, could be counterbalanced by applying a different cooling geometry or using different materials. The proposed parameterization approach therefore seems reasonable for creating different parameter sets in this phase of research. The feasibility of all designed components is also discussed with the manufacturer in the course of this work.

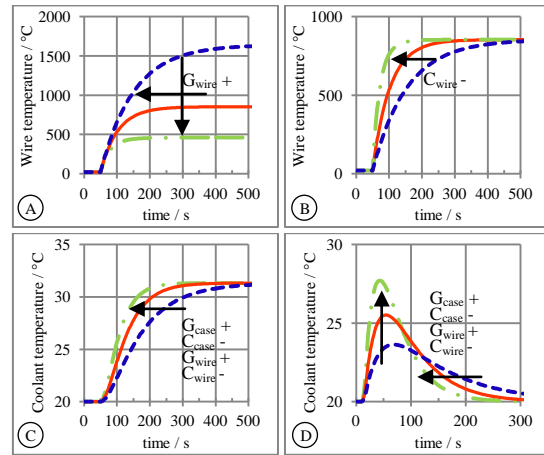

Figure 4: Impact of model parameters on thermal behavior of brake resistor

2.2 Influences on efficiency potential

The efficiency potential mainly depends on the amount of recuperative energy, the required electric power for heating and the charging capability of the traction battery. The following chapter shows how these parameters are linked to vehicle properties and use cases. As a result, three different brake resistor components are derived.

2.2.1 Vehicle specifications

The specific vehicle properties have a large impact on the achievable efficiency gain through brake resistor application. Assuming identical deceleration, the maximum recuperation power is proportional to the vehicle mass. The demand for heating energy on the other hand is related to the layout and volume of the passenger cabin.

To quantify these different influences, three vehicle categories are created for the simulation. They are based on the U.S. EPA vehicle size classes [5] whereas the parameters internal volume and mass represent a selection of current battery electric vehicles in series production.

The aerodynamic drag is set to be identical for all cars. It is assumed that the larger cross sectional

area A of the larger cars can be compensated by more beneficial vehicle body shapes leading to lower c_w values. The remaining resistance terms (wheel friction, gear losses) are scaled linearly by the vehicle mass. All vehicles are set to a regenerative deceleration limit of 1.6m/s^2 which is a realistic compromise between efficiency and driving stability and can be fully covered by the available traction power of the electric drive.

Table 1: Properties of selected vehicle categories

	Micro	Compact	Large
Vehicle mass / kg	1100	1600	2100
Internal volume / l	2200	2800	3500
eDrive power / kW	75	105	135
Cell Configuration	1p96s	1p96s	1p96s
Cell Capacity / Ah	40	60	80
$c_w \cdot A / \text{m}^2$	0.6	0.6	0.6
Recu. Limit / m/s^2	1.6	1.6	1.6

The dynamic recuperation availability also depends on the state of the hv-traction battery which is analyzed in the vehicle simulation. For realistic behavior of the Li-ion storage at low temperatures the cell model for vehicle class “Micro” is adopted from previous work on this subject [4]. This model is then used for the other two vehicles with the battery’s internal resistance scaled down linearly with rising capacity. This approach is based on the assumption that the higher amount of active material in the larger cell leads to a lower internal resistance. All three storage models are comprised of 96 cells connected in series (1p96s).

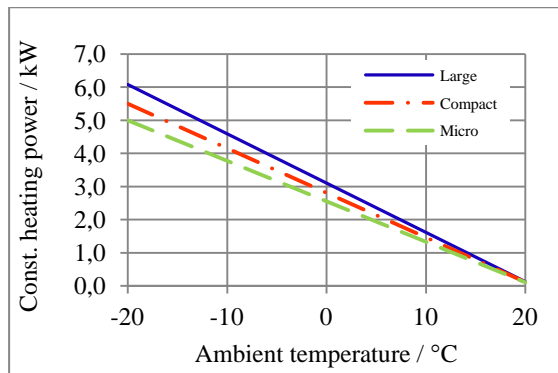

Figure 5: Estimated constant heating power demand

To estimate the necessary heating power as function of the outside temperature and the vehicle size, an approximation suggested by Großmann (equation 5.1 in [6]) is used. Since this equation also takes into account the insulation properties of the vehicle, average values and conversion formulas suggested in [6] are used for evaluation. The resulting constant heat power demand of the

three vehicles is shown in Figure 5. As expected the energy demand for heating rises with increasing cabin volume but it is not directly proportional. In contrast to the much lower cabin size the heating power of vehicle “Micro” decreases by only 22%. Measurements taken with the BMW ActiveE in the course of the research project EFA2014/2 could be used to make plausible the magnitude of the estimated values. These power values are later used as input for the heater core in the vehicle simulations.

2.2.2 Use case selection

For energetic evaluations, drive cycle analysis is a valuable method to show the influence of different driving environments.

Figure 6 depicts simulation results of average electric recuperation power in different common driving cycles. In good approximation it shows that the recuperation energy is directly linked to the vehicle mass, based on the assumptions made in chapter 2.2.1. Apart from the New European Driving Cycle (NEDC), which is known to be less dynamic, the cycles show an average recuperation power between one and three kilowatts depending on the vehicle class. Up to 0°C the average recuperation power is lower than the heating energy demand for all three vehicles. Assuming the charging ability of the traction battery is strongly limited at low temperatures, this extra energy could fully be used for heating purposes. The expected efficiency gain by electric brake resistor is highest if the surplus recuperation power can cover large portions of the heating demand. Therefore the larger vehicle seems to be best suited for this application, e.g. in three Artemis¹ cycles “Urban”, “Rural Road” and “Motorway”.

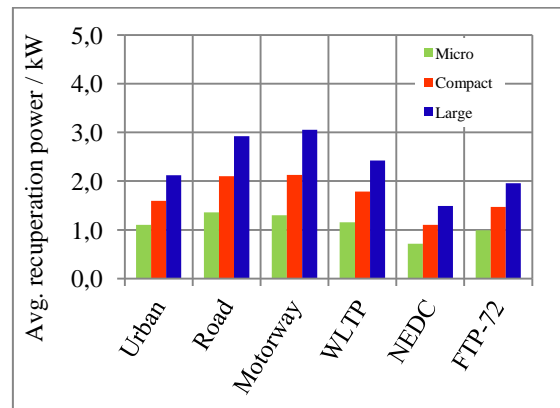

Figure 6: Average electric recuperation in drive cycle

¹ “Assessment and reliability of transport emission models and inventory systems” ([8])

The achievable gain of driving range, however, also depends on the percental efficiency gain in the respective drive cycle. Therefore, cycles that have a high energy demand for traction, e.g. due to a high average speed, profit less from recuperation. Figure 7 shows the ratio between recuperation energy and energy needed to propel the vehicle in the different cycles. It becomes apparent that cycles with lower average speed and many stop and go phases like the ‘‘Artemis Urban’’ profit the most from recuperation and are therefore more interesting for the brake resistor application.

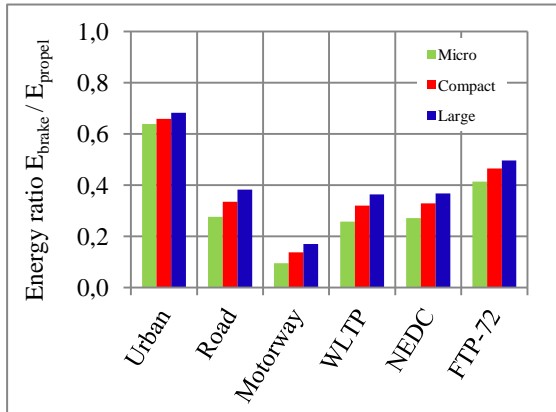

Figure 7: Ratio between brake energy and energy needed to propel the vehicle

The three Artemis cycles are selected for further analysis as they allow a separate evaluation of the different driving environment city, inter-city and motorway. The other cycles WLTP², NEDC³ and FTP-72⁴ are designed to cover an average vehicle usage, which is also visible in

Figure 6 and Figure 7. As they contain a combination of all three driving situations they are less suitable for analyzing individual influences.

2.2.3 Brake resistor selection

As previously mentioned the design parameters used to dimension the electric brake resistor are the continuous power and the resistor time constant. This chapter describes how these requirements can be derived from the vehicle application, using the afore-mentioned energetic approach.

First it is assumed that there are conditions under which the brake resistor has to process the entire recuperation power. Depending on the cell chem-

istry this may be the case at low temperatures or high SOC (state of charge). As the brake resistor has to provide constant heat for the vehicle’s heater core, the time dependent power requirement $P_{BR}(t)$ is a superposition of constant heat power and dynamic recuperation power, cf. equation (2).

$$P_{BR}(t) = \max(P_{BR\ heat}, P_{BR\ dyn.}(t)) \quad (2)$$

To derive the power requirement of one vehicle/cycle-combination, first the power data is filtered with variable widths of moving average filters. Taking the maximum of each respective graph, every filter setting has one specific power requirement to the component. As an example Figure 6 shows the maximum requirement for each filter setting as one data point, marked ‘‘drive cycle requirement’’. The resulting curve shows what a brake resistor with the respective time constant would have to be able to process. For example a $\tau = 6\text{ s}$ resistor would need a continuous rated power of 30 kW whereas with a less dynamic $\tau = 60\text{ s}$ resistor 8 kW would be sufficient. To visualize how one selected resistor fits the entire spectrum of the cycle requirements,

Figure 6 contains three different components for comparison. All three are suitable for this specific application but it is apparent that with the simple energetic approach there is no single combination of τ and $P_{cont.}$ to fit the entire spectrum of the cycle requirements without over dimensioning.

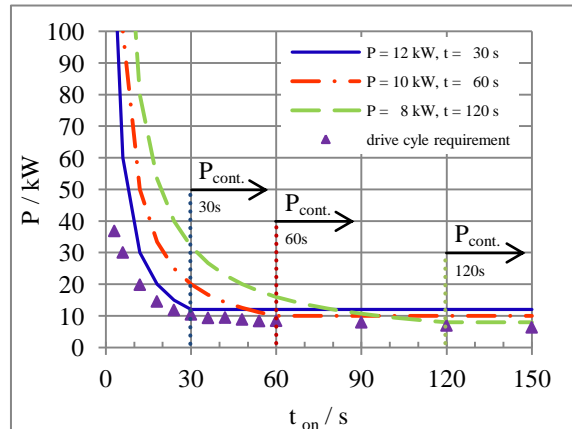

Figure 8: Exemplary comparison of brake resistor performance and drive cycle requirement

For this paper the less dynamic components are selected. On the one hand the expected dynamics in the coolant temperature will be lower which causes less disturbance on the heater core control. Secondly, the higher dynamic resistors also have the higher continuous power rating. According to REO AG the continuous power currently has the biggest impact on the component’s size and

² ‘‘Worldwide harmonized Light vehicles Test Procedures’’, final version expected 2013/2014 ([9], [10])

³ ‘‘New European Driving Cycle’’ ([10])

⁴ ‘‘Federal Test Procedure’’ ([10])

weight. Low values of $P_{cont.}$ are therefore favorable for automotive application, although they lead to a higher over dimensioning in the short time scale (cf. Figure 8).

Table 2: Selected brake resistor parameters

	Micro	Compact	Large
Cont. Power / kW	6	8	10
Time Constant / s	120	120	120

The chosen brake resistor components for each vehicle category are listed in Table 2. They are designed to fully fit the power requirements of the Artemis Rural Road cycle at maximum heat power demand. The respective simulation model parameters are derived according to the method presented in chapter 2.1.3.

2.3 Assessment of efficiency potential

This chapter presents the evaluation metric applied to quantify the efficiency potential of the brake resistor application. It is shown how the dynamic vehicle simulation is used to determine the efficiency gain compared to a vehicle setup without braking resistor.

2.3.1 Dynamic vehicle simulation

The dynamic vehicle simulation is implemented in Modelica® and carried out in Dymola®. The simulation environment is adapted from previous work (cf. [7]) and is supplemented with the brake resistor model described in chapter 2.1.2 and a heating controller (cf. chapter 2.3.2). The power demand of the heater core is implemented as a constant heat flow according to Figure 5.

A schematic of the simulation setup is shown in Figure 9. The longitudinal dynamics model is based on efficiency maps for the e-machine and power electronics in combination with an equivalent circuit model for the Li-ion traction battery. Special attention is laid on the low temperature behavior of the battery including a realistic behavior of the operating strategy determining the time dependent power limits. The parameterization and validation of the battery model can be found in [4].

As indicated in chapter 2.2.1 the vehicle model including the resistance calculation, the battery model and the parameter maps of the electric drive is scaled to the three selected vehicle categories.

The goal is to create a customized simulation environment for every vehicle that can adequately represent the impact of the different vehicle

masses on the driving efficiency. The efficiency itself is calculated by relating the net energy⁵ (cf. Figure 9) to the distance covered in the respective drive cycle.

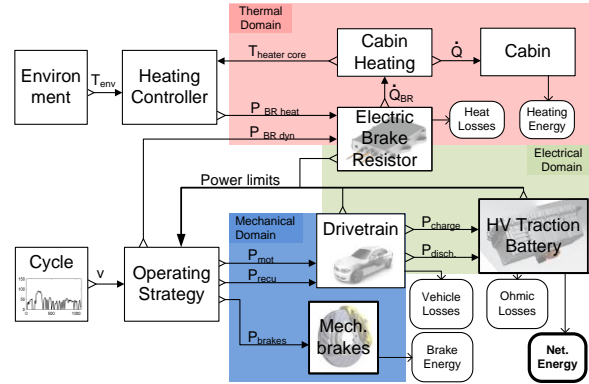

Figure 9: Schematic of simulation environment

2.3.2 Brake resistor control

The essential part of this study is the brake resistor control. Its tasks are to convert the surplus recuperation energy into useful heat and provide the necessary average heat for the cabin heating. In the simulation environment shown in Figure 9 these two tasks are included in the sub models “Heating Controller” and “Operating Strategy”.

The working principle of the two functions is visualized in Figure 10:

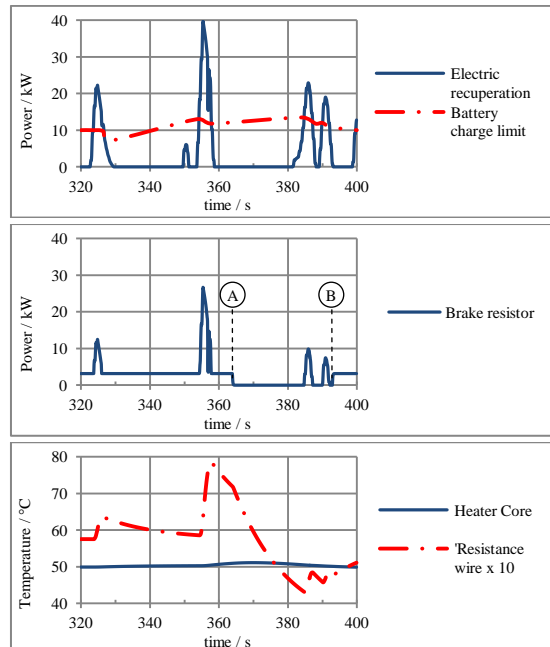

Figure 10: Visualization of brake resistor control

⁵ Net. Energy corresponds to the electrochemical energy drawn from the Li-ion battery. It includes all energy losses on vehicle and battery level.

1. The heating controller actuates the braking resistor to keep the heater core temperature above a threshold of 50 °C. In this situation a constant power value ($P_{BR\ heat}$) of 3.2 kW is needed.
2. The operating strategy compares the recuperation with the current charging ability of the battery. It dynamically actuates the brake resistor ($P_{BR\ dyn}$) to process the excessive recuperation power.
3. As a result of the recuperation peaks the heater core temperature rises above 50 °C at $t=360$ s. This allows the heating controller to completely turn off the heating via brake resistor between the points in time A and B.

With this control strategy the surplus recuperation energy can be utilized by using the thermal system as an energy buffer. As this leads to a reduced net. energy demand from the hv battery the overall driving efficiency is increased.

2.3.3 Metric

The effective efficiency gain is determined by comparing two drive cycle simulations with identical start parameters. The first simulation is done using the brake resistor to process the surplus recuperation heat which leads to the net. energy turnover $E_{net, BR}$. In the second simulation run the limited recuperation availability is compensated by applying the vehicle's friction brake. The resulting energy turnover E_{net} is then used as reference in equation (3) to calculate the efficiency gain η_+ .

$$\eta_+ = \frac{E_{net} - E_{net, BR}}{E_{net}} \cdot 100\% \quad (3)$$

This evaluation is carried out for all three vehicles for the three Artemis driving cycles. To determine the influence of varying start parameters all combinations of environment temperature and start SOC of the battery are simulated. It is assumed that the battery temperature is equal to the environment temperature at the beginning of the drive cycle. This represents a scenario in which the electric vehicle is parked outside with no preconditioning program before start.

3 Simulation results

All simulations are carried out with varying start SOC and ambient temperatures using iteration steps of 5 % and 5 K. As a first result, all selected brake resistor components are able to fulfill the power requirements of the drive cycles. The power parameters are derived from the rural road

cycle but also suit the motorway cycle since the recuperation is never fully restricted.

The simulated efficiency gains are displayed as 2D surface plots in Figure 11 to Figure 13. The graphics show that for the selected configurations the brake resistor strategy reduces the net. energy demand up to fourteen percent depending on the start parameters.

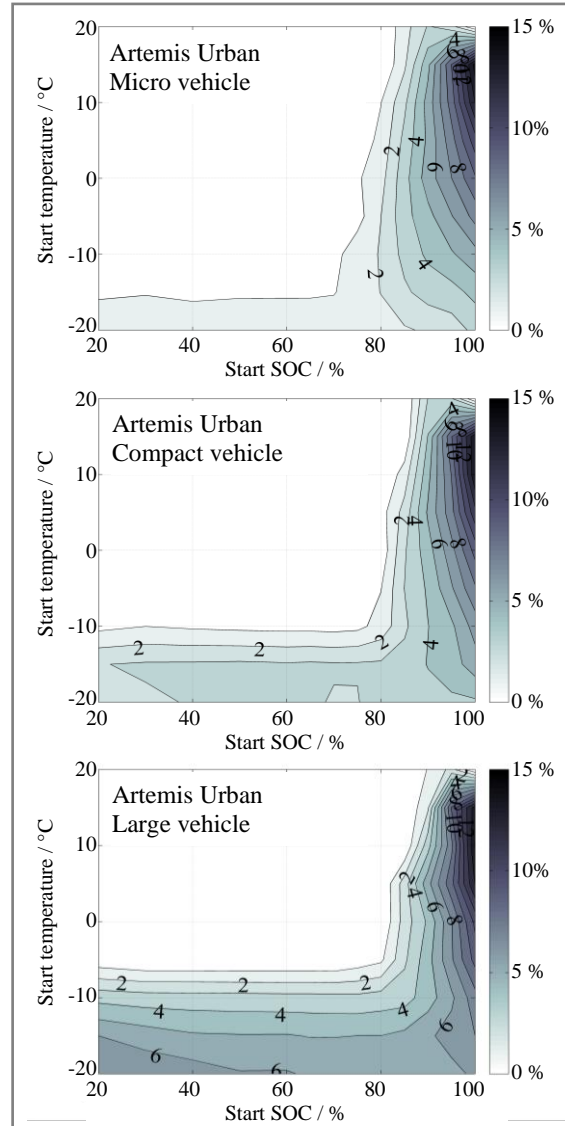

Figure 11: Efficiency gain in Artemis Urban cycle

The conditions in which the brake resistor strategy offers an advantage are generally located in the two areas where recuperation is limited due to charge power restrictions:

- At high start SOC the battery's voltage limitation is often reached limiting recuperation availability. The efficiency gain by using the brake resistor is highest at temperatures between 0 and 20 °C. Here the heating demand

can be covered by the excess recuperation energy to a large extent (cf. Figure 5).

- The second area of efficiency potential lies at low temperatures where current limitations occur. The potential is slightly increased at low SOC. Here the current levels are reached faster because the current values increase at the lower voltage level.

Depending on the combination of vehicle and drive cycle these two areas are more or less distinct. Several patterns can be observed:

- In the urban environment areas of high SOC show the highest efficiency gain values. Frequent stop-and-go situations in combination with a low average speed cause voltage based limitation of recuperation for an extended period of time.

- In the rural road scenario the areas of low temperature become more dominant.
- Higher energy turnover causes the battery voltage level to drop quickly which acts as a voltage buffer during recuperation. Therefore current based limitation is more likely to occur. This effect is also driven by the higher average speed since the average discharge current is higher than in the urban drive cycle.
- The motorway cycle shows no relevant efficiency gain in the area of voltage based recuperation limit. Efficiency gain is only visible for low temperatures. Due to the high average speed the motorway cycle shows the lowest efficiency values. However, due to the high average current flow during driving the area of efficiency gain already becomes apparent at temperatures between 0°C and +10°C.

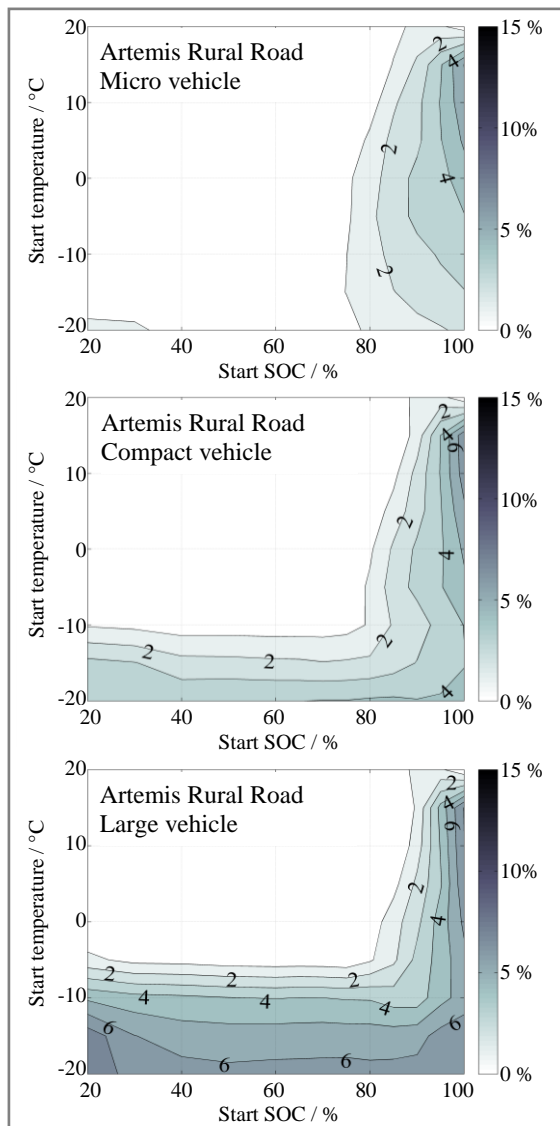

Figure 12: Efficiency gain in Artemis Rural Road cycle

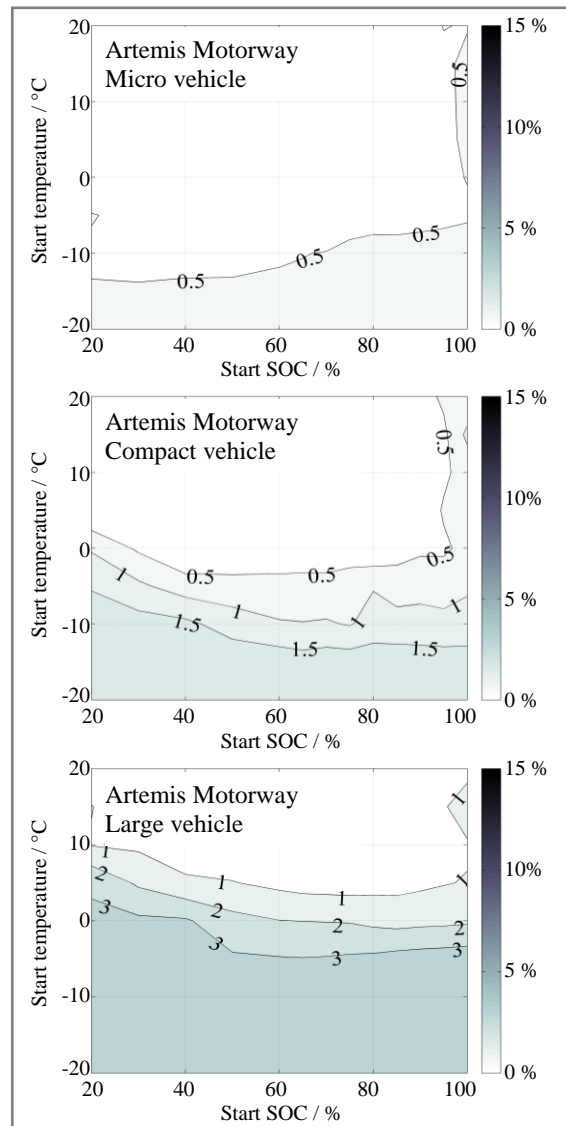

Figure 13: Efficiency gain in Artemis Motorway cycle

The influence of the vehicle category on the efficiency potential is similar in all three cycles:

- The heavier vehicles show higher maximum values of energy savings in all three cycles.
- Due to the higher current flow the heavier vehicles show more potential for savings at low temperatures.
- The areas of high SOC show similar potential for the three vehicles.

4 Discussion

As the results reveal there are many conditions in which the electric brake resistor application has the potential to increase vehicle efficiency by several percent. In an SOC range between approximately 80 to 100% the recuperation is frequently restricted, especially in an urban driving environment. This effect is most apparent for the lightest vehicle analyzed, since the area of efficiency gain is largest. A battery electric vehicle that is mainly used for urban transportation could therefore benefit from the use of an electric brake resistor. Especially if it is being kept on a high SOC, e.g. for car sharing or fleet application.

Surprisingly, the maximum efficiency gain of this application does not occur at the lowest temperature where recuperation is most limited (cf. [2]). It rather lies between +5 °C and +15 °C, where the excess recuperation energy can cover a larger part of the energy demand from the heating system. Note that this evaluation is based on a constantly high comfort level in the passenger cabin with constant power demand for all environment temperatures. Setting the cabin temperature to a slightly lower level could therefore increase the percental efficiency gain at low ambient temperatures. Also, improving the vehicle's insulation can have a similar effect.

The other field of application for the brake resistor is the area of charge current limitation due to low temperatures. Again, the urban driving scenario shows the highest potential, but also the motorway reveals some potential in these operation points. Especially in the urban driving environment the temperature of the traction battery has shown to increase only slightly during driving due to the low average power demand. Vehicles that are being parked outside in winter could therefore benefit permanently from the presented strategy.

As the quantitative results of this evaluation are strongly linked to the hv battery's behavior, the achievable efficiency gain is always dependent on the actual vehicle's configuration. Among

others the choice of cell-chemistry or cell setup may alter the balance between areas of current based and voltage based charge limitations. For example, own measurements have indicated that a different cell chemistry by another manufacturer shows less voltage based limitations whereas the area of current based limitation is far larger than the results shown here. Also the evaluation presented here is done with brand-new battery cells. With progressing age the internal resistance of the hv battery increases, which will extend the margin of SOC in which the brake resistor can offer a gain in efficiency. To highlight this effect Figure 14 shows the Urban simulation carried out with an exemplary increase of the cell's internal resistance of 50%.

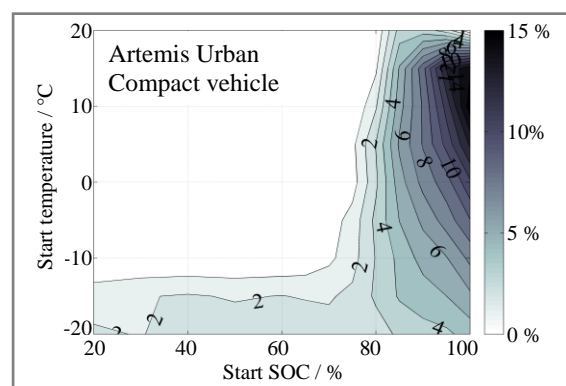

Figure 14: Efficiency gain with increased internal resistance of hv battery

All in all, the braking resistor has the potential to mitigate the negative effect of low temperatures and cell aging on energy efficiency. The quantitative efficiency gain, however, needs to be evaluated for a specific vehicle configuration.

The results also reveal that there is a large area where the brake resistor offers no energetic advantage. Therefore additional research is necessary to assess the average efficiency gain for a specific environment throughout the year. As one possible outcome it may also be favorable to offer the brake resistor component as optional equipment, e.g. for Nordic countries or for car owners that don't have access to a heated garage.

As far as the component development is concerned there is research ongoing to further reduce the heat loss over the casing of the resistor. By applying different case materials and cooling concepts or controlling the separate heating wire elements individually the goal is to reach the same efficiency as a conventional water heater. As one outcome of this paper it is shown that depending on the vehicle size and weight a constant power rating of six to ten kilowatts is sufficient to cover the full

requirements of heating and recuperation in realistic driving cycles. With this input the next generation of brake resistors can now be optimized further with respect to efficiency, size and weight.

Note that this paper is focused on the efficiency gain of the brake resistor application. For a thorough cost-benefit-analysis other previously mentioned aspects should be evaluated also:

- Using the brake resistor to compensate for limited recuperation can reduce the wear of the conventional brake system.
- As the brake resistor can be used to generate heat directly from recuperation power the energy turnover of the traction battery can effectively be decreased, which could lead to reduced ageing.
- Less cost intensive traction batteries may be applied since the charging ability at low temperatures is less crucial for enabling recuperation.

Acknowledgement

This work is supported in part by the German Bundesministerium für Bildung und Forschung (Federal Ministry of Education and Research) as part of the research project EFA2014/2 (Energy Efficient Driving 2014 – phase 2) [3].

The authors also wish to express their appreciation to “REO Inductive Components AG” for supporting this work with expert know how and extensive measurement data.

References

- [1] F. Kessler, E. Hockgeiger, J. Schröder, D. Strobl, J. Tachtler, and F. Vogel, “The new BMW electric powertrain in the ActiveE,” *20th Aachen Colloquium Automobile and Engine Technology*, 2011.
- [2] J. Lieb, A. Wilde, and B. Bäker, “Causes for torque degradation during deceleration and the effect on the driving range of battery electric vehicles,” in *Energy Efficient Vehicles Conference*, 2012.
- [3] R. Huber and T. Knoll, “Presse-Information der Projektpartner im Forschungsprojekt „Energieeffizientes Fahren 2014 – Reichweitenerhöhung von Elektrofahrzeugen“ (EFA 2014/2),” *Press release*, 2012. [Online]. Available: <https://www.press.bmwgroup.com>. [Accessed: 09-Jan-2013].
- [4] J. Lieb, F. Czuppa, S. Knoll, J. Schröder, and B. Bäker, “Simulating low temperature behavior of high voltage

traction batteries – The challenge of real time efficiency estimation,” in *Conference on Future Automotive Technology Focus Electromobility*, 2013.

- [5] U.S. Environmental Protection Agency, “EPA Vehicle Size Categories.” [Online]. <http://www.fueleconomy.gov/feg/info.shtml#sizeclasses>. [Accessed: 12-Jul-2013].
- [6] H. Großmann, *PKW-Klimatisierung*, 1st ed. Berlin: Springer Berlin Heidelberg, 2010.
- [7] J. Lieb, F. Czuppa, and B. Bäker, “Modeling low temperature behavior of high voltage traction batteries and the effect on vehicle efficiency.”
- [8] M. André, “Real-world driving cycles for measuring cars pollutant emissions -- Part A: The ARTEMIS European driving cycles,” *Report INRETS-LTE 0411*, 2004.
- [9] WLTP Sub-group on the Development of the Harmonized driving Cycle (DHC), “DHC 18th session.” [Online]. Available: <https://www2.unece.org/wiki/display/trans/DHC+18th+session>. [Accessed: 12-Jul-2013].
- [10] ECOpoint Inc, “Worldwide engine and vehicle test cycles.” [Online]. <http://dieselnet.com/standards/cycles>. [Accessed: 07-Feb-2013].

Authors



Johannes Lieb works at BMW in the development of hybrid and electric drivetrains. Since 2011 he is pursuing his PhD in automotive technology at the TU Dresden. His field of research is energy management in the course of brake energy regeneration.



Egor Sawazki works at Continental, Powertrain division in the strategy & technology department. He is working as model based function developer for thermal management of electric vehicles. He studied engineering at the University of Paderborn.



Dr. Martin Brüll works at Continental, Powertrain division in the strategy & technology department. He is project manager in the EFA2014/2 project predictive thermal management strategies for EVs. He received his PhD in the field of radio astrophysics.



Prof. Dr. Bernard Bäker is chairholder of the department of Vehicle Mechatronics of the TU Dresden. His present research focus ranges from energy management strategies to vehicle e/e architectures. He received his PhD on energy and information management.