

## **Design considerations for fast AC battery chargers**

Manuele Bertoluzzo<sup>1</sup>, Giuseppe Buja<sup>2</sup>, Giovanni Pedè<sup>3</sup>

<sup>1</sup>*Department of Industrial Engineering, via Gradenigo 6a, 35131, Padova, Italy, manuele.bertoluzzo@unipd.it*

<sup>2</sup>*Department of Industrial Engineering, via Gradenigo 6a, 35131, Padova, Italy, giuseppe.buja@unipd.it*

<sup>3</sup>*ENEA, Laboratorio Veicoli a Basso Impatto Ambientale, Santa Maria di Galeria (Roma), Italy, giovanni.pede@enea.it*

---

### **Abstract**

Proliferation of electric vehicles (EVs) is tightly associated to the fast charging of their batteries. Both high-power DC and AC supply options are envisaged for the fast charging of the EV batteries, each of them having different features. This paper considers the AC supply option and deals with the main issues that it poses like an onboard high-power battery charger and its impact on the grid. To face with these issues, a possible arrangement for the battery chargers consists in the integral use of the inverter bound to supply the traction motor and in the proper conditioning of the current absorbed from the grid. In the paper, design considerations for this arrangement are given and applied to the case study of a purely electric, mid-size car.

*Keywords: Electric vehicle, AC battery charger, Fast charging*

---

### **1 Introduction**

Electric vehicles (EVs) rely on the grid to charge their batteries. Charging process takes much more time than refueling vehicles with an internal combustion engine and this significantly reduces the availability of the EVs to the drivers [1]. In order to guarantee a reasonable availability, today's EVs are equipped with lithium-ion batteries supporting a charging current that, expressed in amps, is equal to  $xC$ , where  $C$  is the capacity of the battery and  $x$  is a multiplication factor greater than 1 [2].

Mid-size EVs have batteries with a stored energy of tens of kW-h. Their charging from a domestic 3 kW socket-outlet lasts from 6 to 8 hours, which is acceptable for an overnight charging. For a shorter charging, AC charging stations with power up to 22 kW are already placed on the roads whilst charging stations with power up to 43 kW for AC supply, and to 50 kW for DC supply are planned to be placed [3]. By them, batteries can be charged to 50% of their full capacity in

about ten minutes or less, or to 80% in about half an hour. The AC supply requires an EV-onboard battery charger. The high-power AC charging poses two issues on this matter: i) cost and bulkiness of the charger that should not affect volume, mass and price of the EVs, and ii) concern on the power quality of the grid service while batteries are charged.

The paper deals with the arrangement of a 43 kW AC battery charger that effectively faces the above-mentioned issues. The arrangement consists in the so-called integral use of the traction inverter, i.e. in exploiting its inherent bidirectional energy flow properties to reconfigure it as an AC battery charger of 43 kW. In detail, the paper is organized as follows: Section 2 describes the charging Modes 3 and 4 and the design requirements set by the grid codes; Section 3 discusses the topology of an integral AC battery charger; Section 4 presents some applicative aspects for a high-power AC battery charger; Section 5 introduces the purely electric,

middle-size car utilized as the case study; Section 6 expounds design considerations on an integral AC battery charger for the case study; Section 7 concludes the paper.

## 2 Design Requirements

### 2.1 Charging Modes

IEC 61851-1 standard defines four charging Modes for EVs, numbered from 1 to 4 [4]. For each Mode, the standard specifies the maximum socket-outlet voltage and current. High-power battery chargers must agree with Modes 3 and 4, in particular they must utilize a dedicated supply equipment. Mode 3 is expressly postulated for the high-power AC charging and encompasses charging of an EV from a three-phase 400 V grid with a current of 63 A per phase, delivering a power of 43 kW. Mode 4 refers to a DC supply and encompasses the charging of an EV with voltage, current and maximum power of 500 V, 125 A and 50 kW, respectively [5].

### 2.2 Grid Codes

Two different standards apply for the allowed distortion of the current absorbed by an AC battery charger in Mode 3. They are IEC 61000-3-12 for a current between 16 A and 75 A per phase, and IEC 61000-3-2 for a current lower than 16 A per phase [6], [7].

Standard IEC 61000-3-12 establishes the admissible magnitude of the individual current harmonics as a ratio of the fundamental component and fixes the admissible values for the distortion factors THD and Partial Weighted Harmonic Distortion (PWHd). THD is computed by accounting for the first 40 current harmonics. PWHd, defined in (1), is introduced to insure that the current harmonics of order higher than 13 are sufficiently reduced without defining individual limits for them.

$$PWHd = \sqrt{\sum_{n=14}^{40} n \left(\frac{I_n}{I_1}\right)^2} \quad (1)$$

Table1: IEC 61000-3-12 current harmonic limits.

Short circuit ratio	Admissible individual harmonic current $I_n/I_1$ [%]							Admissible harmonic current distortion factors [%]	
	$I_3$	$I_5$	$I_7$	$I_9$	$I_{11}$	$I_{13}$	THD	PWHd	
33	21.6	10.7	7.2	3.8	3.1	2	23	23	

Table 2: IEC 61000-3-2 current harmonic limits.

Admissible individual harmonic current [A]						
Odd Harmonics						
$I_3$	$I_5$	$I_7$	$I_9$	$I_{11}$	$I_{13}$	$I_n (15 \leq n \leq 39)$
2.30	1.14	0.77	0.40	0.33	0.21	0.15·15/n
Even Harmonics						
$I_2$		$I_4$		$I_6$		$I_n (8 \leq n \leq 40)$
1.08		0.43		0.30		0.23·8/n

The limits depend on the short circuit ratio at the connection point of the AC battery chargers. Being this point not known a priori, the minimum short ratio deliberated in the standard (equal to 33) should be used. The corresponding limits for the current harmonics of odd order together with the admissible harmonic distortion factors are listed in Tab.1. For the even harmonics, the relative values of the harmonics up to 12<sup>th</sup> order shall not exceed 16/n %, where n is the harmonic order. Above the 12<sup>th</sup> order, the even harmonics are taken into account by THD and PWHd in the same way as odd harmonics.

Differently from IEC 61000-3-12, the standard IEC 61000-3-2 establishes absolute values for the admissible magnitude of the current harmonics and states that the limits must be met even if the fundamental component of current is zero. The current harmonic limits established by the standard IEC 61000-3-2 are listed in Tab.2.

## 3 Integral Battery Charger

Because of the power levels involved in the high-power AC battery chargers, current harmonic limits are quite stringent for them. Three-phase diode rectifiers, even if endowed with DC link voltage control, are not appropriate [8] and the PWM rectifiers, also called active front-end converters, appear as an effective solution since they are able to absorb from the grid a current that is nearly sinusoidal and in-phase with the voltage [9], [10]. Incidentally, they are also largely utilized for interfacing the renewable energy sources, like wind generators and photovoltaic panels, to the grid.

Modern EVs are propelled by three-phase AC traction motors fed by inverters, which are just DC/AC converters with bidirectional power flow capabilities. Therefore it is only too natural to operate them as PWM rectifiers with the purpose of charging the batteries of the EVs [11], [12]. Furthermore, the drivetrains of the mid-size EVs have a power of tens of kW; this means that not only the traction motors but also the inverters

feeding the traction motors (traction inverters) are sized to stand up to the conversion of a power of 43 kW.

Besides being attractive for facing the issue of volume, mass and prize posed by a high-power AC battery charger, the integral PWM rectifiers face the issue of the power quality, as anticipated above.

On the other hand, such an integral use has to reckon with the consistency of the voltage values within the AC battery charger. Indeed, the transistors of the traction inverter are tailored to the voltages of the EV-onboard batteries that are typically of a few hundreds of volts in the mid-size EVs, whereas the voltage that the transistors of the PWM inverters must withstand when connected to a grid at 400V is about two times higher. Therefore the transistors of a traction inverter meant for an integral use must be sized for higher voltage ratings. Moreover, there is a mismatch between the voltages obtained by rectifying the grid and the voltages of the batteries, and hence a voltage adaptation is mandatory.

A power topology for an integral AC battery charger is shown in Fig. 1. It is formed by two stages: a DC/AC converter and a buck chopper. By help of relays, the topology is switched from the traction operation to the charging operation. It is worth to note that the AC charging station does not contain any power equipment inside but only an electronic control unit (ECU) for the management of the charging operation (user identification, grid supply enabling, billing procedure, and so on).

In the traction operation, the three-phase relay on the left hand side connects the middle points of the DC/AC converter legs to the terminals of the

traction motor and the relay on the right hand side connects the battery directly to the DC link; with this configuration, the DC/AC converter acts as an inverter and the buck chopper is not disconnected. In the charging operation, the DC/AC converter is connected to the AC charging station through an AC filter and the buck chopper is connected to adapt the voltage levels; with this configuration, the DC/AC converter acts as a PWM rectifier and the AC filter plays the twofold role of decoupling the grid from the switched voltage at the input of the PWM rectifier and of reducing the high-frequency current harmonics absorbed by the AC battery charger. The AC filter, which is designed in tight association with the PWM rectifier, is aimed at forcing the absorbed current harmonics to meet the IEC 61000-3-12 and IEC 61000-3-2 standards.

### 3.1 Rectified grid voltage

Let the AC filter be constituted of a three-phase system of inductors  $L$ , as shown in Fig.1. For the PWM rectifier to work correctly, the magnitude  $V_i$  of the fundamental component of voltage at the input of the PWM rectifier must be higher than the grid voltage  $V_g$  for any current  $I_i$  entering into the PWM rectifier, as illustrated by the phasor diagram of Fig. 2. Consequently, the DC link voltage  $V_{DC}$  must be higher than the peak magnitude of the line-to-line grid voltage  $V_{gg,p}$  of a confidence factor  $c_f$  that accounts both for the voltage drops across the AC filter and the power switches, and for the changes in the grid voltages. Then it is

$$V_{DC} = c_f V_{gg,p} \quad (2)$$

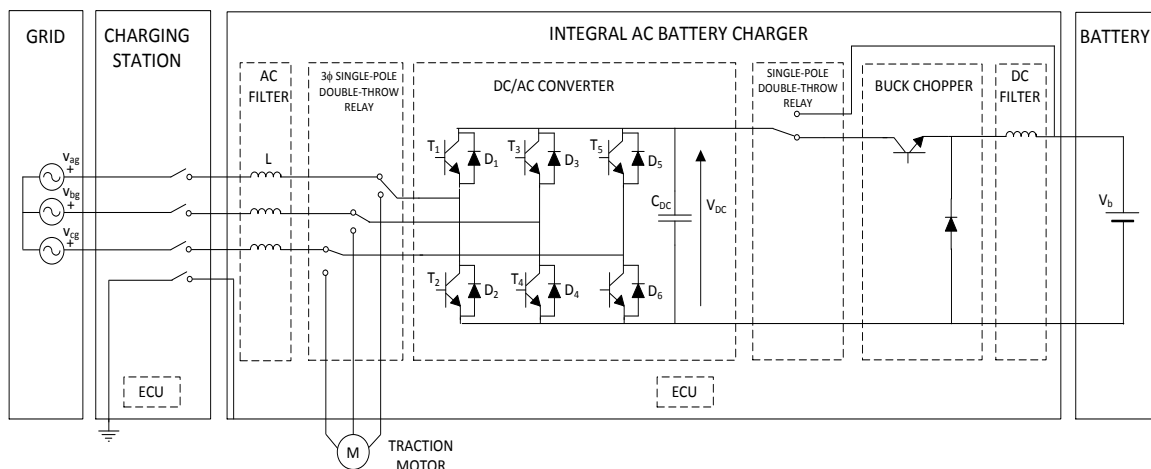

Figure 1: Power topology of an integral AC battery charger.

Eq. (2) leads to another design specification for the AC filter: it should offer a relatively small impedance at the grid frequency in order not to increase appreciably the magnitude requirements for the DC link voltage. For this reason, the inductors are often substituted for by LCL meshes.

Adaptation of the rectified voltage to that one of the battery can be achieved in two ways:

i) by inserting a buck chopper in-between the DC link of the PWM inverter and the battery, as shown in Fig. 1.

ii) by inserting a step-down transformer in-between the grid and the AC battery charger.

### 3.2 Buck chopper

The buck chopper inserted in cascade to the DC link steps down the DC link voltage to that one of the battery. Moreover, it executes i) the control of the battery current in the charging zone at constant current and ii) the regulation of the battery voltage in the charging zone at constant voltage. In executing these tasks, the buck chopper is assisted by a DC filter of inductive type that smoothies the current entering into the battery.

The insertion of a buck chopper and a DC filter in the AC battery charger causes additional losses that produce heat to be handed over and decrease the overall efficiency of the charger; however, these losses do not occur in the traction operation and, hence, do not impair the EV range. Moreover, the buck chopper adds cost and bulkiness to the onboard power electronics circuitry even if they are much less compared to the installation of a dedicated high-power AC battery charger.

### 3.3 Step-down transformer

An alternative solution to the buck chopper is the insertion of a step-down transformer upstream to

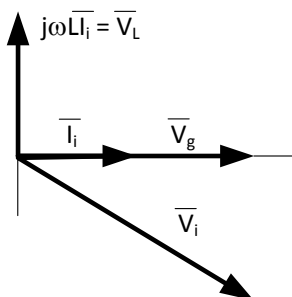

Figure 2: Phasor diagram of electric quantities at the input of the PWM rectifier

the AC battery charger. This solution has two distinct advantages: i) reduction of the voltage to be withstood by the transistors of the DC/AC converter while in charging operation, thus dispensing from a resizing of their voltage ratings, and ii) galvanic separation of the EVs from the grid during the charging operation, thus eliminating the recourse to suitable isolation means to guarantee the safety of the users.

The step-down transformer can be installed either in the AC charging stations or onboard the EVs. In the first hypothesis, the transformer must be equipped with a number of intermediate taps to match with the battery voltages of the various EVs. This installation suffers from some inconveniences such as: i) it calls for a new, complex deployment of the AC charging stations, and ii) it implies the flow of currents higher than 63 A, thus exceeding the intended capacity of the relevant items like cables, plugs and sockets.

The second hypothesis, i.e. the installation of the step-down transformer onboard the EVs, is impractical due to the mass and volume that this would add to the EVs. However, it would have the merits of using a transformer with a fixed turn ratio and of exhibiting higher efficiency than the buck chopper and DC filter set.

### 3.4 V2G capability

As previously pointed out, a DC/AC converter is inherently bidirectional and then can support power transactions with the grid. The capability for an EV to deliver services in favor of the grid is commonly termed as Vehicle-to-Grid (V2G). The main V2G service is the return to the grid of the energy stored into the battery in the presence of peaks in the power demand. By replacing the buck chopper of Fig. 1 with a DC/DC converter of buck/boost type, the whole AC battery charger becomes bidirectional and this enable the transfer of electric energy from the battery to the grid. Note that, even with the buck chopper, the AC battery charger of Fig.1 is still capable of carrying out V2G services that -like the regulation of the grid voltage- do not involve a net transfer of electric energy to the grid over the period. Then, the integral use of the traction inverter gets an EV ready to carry out V2G services.

## 4 Applicative aspects

When the charging operation is selected, the AC battery charger is made fully operating in some steps. After connecting the EV to the AC charging station, a pre-charge resistor, not shown in Fig. 1,

is first inserted in series to the DC link capacitor to limit the inrush current; then a switch in the EV inlet circuitry is closed to accept the connection to the grid; during this step the transistors of the PWM rectifier are kept off and the PWM rectifier acts as a diode rectifier charging the DC link capacitor to the grid peak voltage. Afterwards, the pre-charge resistor is shorted, and the PWM rectifier is activated to charge the DC link capacitor up to the required voltage. Finally, also the buck chopper is activated and the AC battery charger starts to charge the battery.

Charging process is controlled through a pilot signal generated by the AC charging station and conditioned by the EV inlet. The pilot signal has a PWM waveform with information coded in the PWM duty-cycle. It provides control functions like continuity of the power connection and current availability of the AC charging station, as mandated by the standard for Mode 3.

Besides handling the startup of the AC battery charger and regulating phase and magnitude of the fundamental component of current absorbed by the PWM rectifier, the ECU of the AC battery charger exchanges data with the battery management system (BMS) of the EV and monitors the pilot signal. The data that the ECU receives from the BMS, commonly also coded in a PWM form, concern the state of the battery and are used to set the voltage/current references for the PWM rectifier.

## 5 Case Study

As a case study, the Leaf electric car has been selected. Leaf, which is depicted in Fig. 3, is a 5-doors hatch back sedan manufactured by Nissan Company; it is propelled by a PM synchronous motor and mounts a Li-ion battery pack based on the NMC (Nickel, Manganese, Cobalt) chemistry. The characteristics of battery and motor found in data sheet are reported in italic type in Tab. 3, while the data in plain type are derived in next



Figure 3: Nissan Leaf.

Subsection.

The battery pack of Leaf is formed by 192 cells organized in 48 modules. The four cells of each module are placed in a 2-series x 2-parallel architecture so that the battery pack has a 96-series x 2-parallel structure. The cells have a nominal voltage of 3.7 V, a cut-off voltage of 3 V and can be charged up to 4.1 V without affecting their working life, the maximum value of the charging voltage being 4.2 V. Therefore the battery voltage goes from a maximum value of 400 V to a minimum value of 250 V, with a nominal value of 345 V. Charging and discharging currents of a NMC-based lithium battery can reach 5 C in steady state and 30 C in pulse mode.

Charging is accomplished via a port located at the front of the car. Completely replenishing the battery requires 4 hours via a 220 V socket-outlet with a 6.6 kW onboard charger (optional on the S, standard on the SV and SL trims) complying with Mode 2. An available quick charge port allows charging of the battery to 80% capacity in 30 minutes at public charging stations equipped with a DC Quick Charge (50 kW) complying with Mode 4.

### 5.1 AC battery charger

In the framework of a project financed by the Italian Ministry for Industry, “Ricerca di Sistema”, which deals with electro mobility, an AC on-board battery charger arranged according to the scheme of Fig.1 and ruled to according Mode 3 has been studied for the Leaf, for comparative assessment with the standard Mode 4. Then, the maximum current that it can absorb from the AC charging station is 63 A. With an allowed excursion of the grid voltage from 360 to 440 V, the maximum power that the AC battery charger can draw varies from 39 kW to 48 kW, respectively.

Table.3: Battery pack and motor characteristics.

<b>Battery pack</b>	
<i>Nominal voltage</i>	345 V
<i>Maximum voltage</i>	400 V
<i>Minimum voltage</i>	250 V
<i>Stored energy</i>	24 kW·h
<i>Maximum power</i>	90 kW
Nominal current	69 A
Maximum current	360 A
<b>Traction motor</b>	
<i>Peak power</i>	80 kW
<i>Peak torque</i>	280 N·m

From the data on the nominal voltage and the stored energy in Tab. 3, the nominal current of the battery results in about 69 A. When the maximum power is delivered at the minimum battery voltage, the current is 360 A, i.e. about 5 C that is just the upper limit of the NMC lithium chemistry. The same current value is expected for the maximum charging current.

## 5.2 Traction drive

PM synchronous motors are appreciated for their high efficiency that can reach values of about 0.95 and more. Efficiency of the Leaf traction drive, i.e. of the traction motor and inverter set, can be estimated in 0.88, which is exactly the ratio between the peak power of the motor and the maximum power of the battery pack. It can be argued that, in the view of avoiding a prolonged discharge of the battery at the upper limit of its capacity, development of the peak power from the motor is accepted for battery voltage equal to or greater than its nominal value, with a corresponding current delivery of 260 A or less, i.e. of about 2.7 C or less.

The peak power of the traction inverter equates the maximum power of the battery pack. It is common rule for the electric traction drives that the peak power is about twice the nominal power; then the heat removed out from the traction inverter should be of 45 kW under nominal conditions. Taking into account that i) the transistor losses are strictly depending on their current and ii) the transistor current in traction operation is much larger than in charging operation due to the lower operating voltage, it turns out that traction inverter can tolerate well the losses when used as a PWM rectifier even at the maximum power of 48 kW.

## 6 AC battery charger

### 6.1 Charging process

Normal charging of the lithium-ion battery encompasses two zones, namely the constant current zone (CC) zone, which can be travelled at the maximum allowable battery current, and the constant voltage zone (CV) zone, which is travelled at the maximum battery voltage. The two zones are sketched in Fig. 4, where  $V_B$  is the battery voltage,  $V_{B,M}$  is the maximum battery voltage,  $I_B$  is the battery current,  $I_{B,M}$  is the maximum allowable battery current and  $P_B$  is battery power.

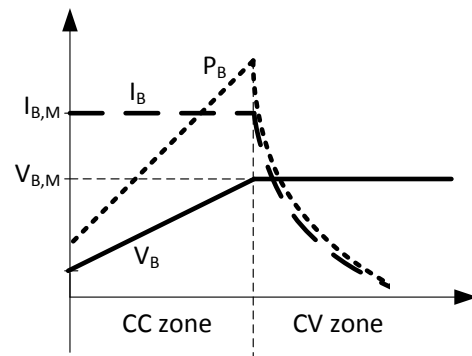

Figure 4: Battery voltage, current and power during the normal charging process.

In the case study, the battery can not be charged at the maximum allowable battery current because this would require drawing a power greater than 43 kW from the AC charging station. Indeed, even by neglecting the losses in the AC battery charger and by drawing from the grid the maximum power of 48 kW, it comes out that the battery charging current ranges between 121 A and 168 A depending on the battery voltage. This means that the charging process is limited by the power of the AC charging station.

Profiles of the battery voltage, current and power during the charging process under power limitation are sketched in Fig. 5, where  $P_{AC}$  is the AC charging station power. In the first zone, the charging process takes place at constant power, equal to the power of 43 kW, and this is obtained by decreasing the charging current as the battery voltage increases. As for the normal CC charging, the charging process in this zone ends when the battery reaches the maximum voltage. Travelling this zone takes a longer time than in the normal charging due to the lower charging current. Furthermore, the current at the completion of this zone is somewhat less than the maximum allowable battery current so that the voltage drop

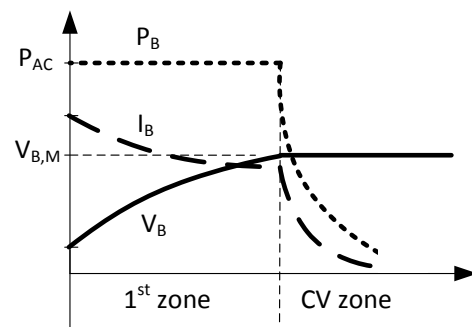

Figure 5: Battery voltage, current and power during the charging process with limited power.

on the battery internal resistance is quite smaller. In the successive zone, the current decreases as in normal CV charging to keep constant the battery voltage at its maximum value. Since the voltage drop on the battery internal resistance at the beginning of the CV zone is smaller than in the normal charging, the charging process in this zone is shorter under power limitation.

## 6.2 AC battery charger voltage sizing

The DC link voltage for the scheme of Fig.1, obtained by choosing a confidence factor of 1.15 in (2), is

$$V_{DC} = c_f V_{gg,p} = 700 V \quad (3)$$

and imposes the selection of transistors rated for 1200 V whilst for the traction operation a voltage rating of 600 V would be enough.

## 6.3 AC filter sizing

In charging operation, the traction inverter operates as a PWM rectifier connected to the grid by means of an AC filter that, at a first attempt, can be implemented with three inductors L designed to satisfy the requirements of Tab. 1 and 2.

Computer simulations demonstrate that such kind of AC filter is able to maintain the current harmonics and the distortion parameters within the limits of Tabs.1 and 2 for a switching frequency of the PMW rectifier of a few kHz, provided that the inductors are of about 2 mH or greater. On the other hand, the windings of the PM synchronous motors have an inductance that, for motors of power and voltage values similar to the ones of the motor installed in the Leaf, is between 2 mH and 4 mH. It is then possible to conceive the exploitation of the windings of the traction motor to implement the AC filter, under the assumption that their neutral point N is accessible and the rotor can be mechanically locked. The topology is shown in Fig. 6 and utilizes, like in Fig. 1, a three-phase, single-pole

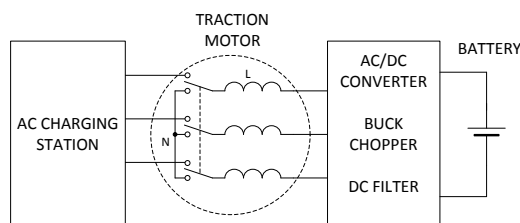

Figure 6: Traction motor windings used as AC filter.

double-throw relay to switch from traction to charging operation, where here one of the throws of the relay is constituted by the terminals of the motor windings connected to N. This represent an integral use of the traction motor that, like for the traction inverter, requires a suitable sizing of the motor winding voltage, i.e. requires that they are isolated for the grid voltage.

## 7 Conclusions

The paper has dealt with the integral use of the traction inverter of an EV as a PWM rectifier to arrange a high-power AC battery charger. It has been explicated the twofold convenience of such an arrangement: i) moderate increment in mass, volume and cost of the power electronics onboard an EV compared to the installation of a dedicated high-power AC battery charger, and ii) appropriateness of the resulting rectifying topology in meeting the requirements for the current limits provided for by the standards. Design considerations on power and voltage ratings of a traction inverter intended to an integral use have been presented. The case study of a mid-size electric car, namely the Nissan Leaf, has been investigated and supported with design data.

## Acknowledgment

ENEA carried on the activity of Fast Charging in the framework of a program promoted and funded by the Italian Ministry for Industry, “Ricerca di Sistema”.

## References

- [1] C.Botsford and A.Szczepanek, “Fast charging vs. slow charging: Pros and cons for the new age of electric vehicles”, Proc. of Electric Vehicle Symposium (EVS) 24, 2009, pp. 1-9.
- [2] X.Chen W.Shen, T.T.Vo, Z.Cao, and A.Kapoor, “ An overview of lithium-ion batteries for electric vehicles, Proc. of Power & Energy (IPEC), 2012, pp. 230-235.
- [3] M.Yilmaz and P.T.Krein, “Review of Battery Charger Topologies, Charging Power Levels, and Infrastructure for Plug-In Electric and Hybrid Vehicles”, IEEE Transactions on Power Electronics, Vol. 28, No. 5, pp. 2151 – 2169, May 2013.
- [4] IEC 61851-1, Electric vehicle conductive charging system – Part 1: General requirements, 2010.

- [5] CHAdeMO Association, “Desirable characteristics of public quick charging”, Tokyo Electric Power Company, 2011.
- [6] IEC 61000-3-2, Electromagnetic compatibility – Limits for harmonic current emission (equipment input current up to and including 16 A per phase).
- [7] IEC 61000-3-2, Electromagnetic compatibility – Limits for harmonic currents produced by equipment connected to public low-voltage systems with input current > 16 A and inferior or equal to 75 A per phase.
- [8] B.Singh, B.N.Singh, A.Chandra, K.Al-Haddad, A.Pandey, and D.P. Kothari, “*A Review of Three-Phase Improved Power Quality AC-DC Converters*”, IEEE Transactions on Industrial Electronics, vol. 51, n. 3, pp. 641-660, June 2004.
- [9] M.Kazerani and N.Wong, “*A review of bidirectional on-board charger topologies for plugin vehicles*”, Proc. of 25<sup>th</sup> IEEE Canadian Conference on Electrical & Computer Engineering (CCECE), 2012, pp. 1-6.
- [10] M.Bertoluzzo, G.Buja, and N.Zabihi, “*Overview on Battery Chargers for Plug-in Electric Vehicles*”, Proc. of 15th Int. Power Electronics and Motion Control Conference, 2012, pp. LS4d.1-7.
- [11] S.Haghbin, K.Khan, S.Lundmark, M.Alaküla, O.Carlson, M.Leksell, and O.Wallmark, “*Integrated chargers for EV’s and PHEV’s: examples and new solutions*”, Proc. of Int. Conf. on Electrical Machines, 2010, pp. 1-6.
- [12] Y.L.Lee, A.Khaligh, and A.Emadi, “*Advanced integrated bidirectional AC/DC and DC/DC converter for plug-in hybrid electric vehicles*”, IEEE Transactions on Vehicular Technology, vol. 58, no. 8, pp. 3970-3980, October 2009.



Giuseppe Buja is a Full Professor at the University of Padova, Italy, with classes on Electric Road Vehicles and Electric Systems for Automation, and the head of the Laboratory of Electric Systems for Automation and Automotive. His scientific interests are power and industrial electronics systems for electric vehicles and energy systems.



Giovanni Pede was graduated in Mechanical Engineering, University “La Sapienza” in Roma, Italy, in 1978. In 1984 he joined ENEA; he presently works in the ENEA Research Center “La Casaccia”, near Rome, where he tests vehicles and automotive components like motors, traction batteries and supercapacitors.

## Authors



Manuele Bertoluzzo is an Assistant Professor at the University of Padova, Italy, where he teaches Enertronics for Energy Engineering. He was in charge of university projects and took part in research program of Relevant National Interest. He is involved in the development of power electronics systems for electric vehicles and of industrial electronics systems for automation applications.