

EVS27
Barcelona, Spain, November 17-20, 2013

SIL, HIL, and Vehicle Fuel Economy Analysis of a Pre-Transmission Parallel PHEV

Jonathan D. Moore and G. Marshall Molen
Mississippi State University
Jdm833@msstate.edu and molen@ece.msstate.edu

Abstract

EcoCAR 2 is a collegiate level Advanced Vehicle Technology Competition which challenges students to re-engineer a General Motors (GM) donated 2013 Malibu Eco as a plug-in hybrid electric vehicle over the course of three years. The competition is organized by Argonne National Laboratory with the U.S. Department of Energy and GM as the headline sponsors. As part of this competition, Mississippi State University (MSU) has designed a pre-transmission parallel PHEV which utilizes a 145 kW permanent magnet brushless DC motor, a 18.9 kWh Li-ion battery, and a GM 1.4 L turbocharged engine which has been tuned for E85 fuel. A supervisory control system has been utilized to interface the hybrid components to the production vehicle, and implements a control strategy enabling charge depleting (CD) and charge sustaining (CS) modes of operation. In order to develop this control strategy and evaluate the vehicle, a simulation model has been constructed in Matlab Simulink for software-in-the-loop (SIL) and hardware-in-the-loop (HIL) simulation. This vehicle model has been constructed using a combination of dSPACE Automotive Simulation Models and MSU developed component models. Each of these component models has been parameterized from manufacturer provided data in order to ensure the accuracy of the vehicle evaluations. An analysis of the vehicle's fuel economy has been performed using SIL and HIL simulation over four drive cycles for CD and CS modes of operation. A combined fuel economy has been calculated according to SAE Standard J1711 for both E85 and gasoline fuels.

Keywords: PHEV, General Motors, Plug-In, SIL, HIL

1 Introduction

EcoCAR 2 is a collegiate level Advanced Vehicle Technology Competition (AVTC) which challenges students to re-engineer a General Motors (GM) donated 2013 Malibu Eco as a plug-in hybrid electric vehicle (PHEV) over the course of three years. Each of the three years of the competition follows the GM vehicle development process (VDP) with each year

focusing on a specific aspect of the VDP: design, integration, and optimization. The competition is organized by Argonne National Laboratory (ANL) with the U.S. Department of Energy (DOE) and GM as the headline sponsors [1].

Mississippi State University has developed a pre-transmission parallel PHEV as part of its participation in the EcoCAR 2 AVTC. The vehicle's hybrid components have been integrated into the 2013 Malibu through the use of a

supervisory controller. Software-in-the-loop (SIL) simulation has been utilized for development of the supervisory control strategy and evaluation of the vehicle fuel economy. Hardware-in-the-loop (HIL) evaluations have been performed to verify the results of the SIL simulations.

1.1 Vehicle Architecture

The pre-transmission parallel PHEV architecture being implemented into the 2013 Malibu utilizes a 145 kW permanent magnet brushless DC motor with an 18.9 kWh Li-ion battery pack. The electric motor is coupled to the transmission through use of a lubricated chain drive and interfaced to a GM 1.4 L turbo charged engine operating on 85% ethanol and 15% gasoline fuel (E85). A one-way clutch is present between the chain drive and the engine and enables the engine to be decoupled from the driveline when it is not in operation. The vehicle utilizes two primary modes of operation: charge sustaining (CS) and charge depleting (CD). In the CD mode the vehicle uses only the electric motor for propulsion. In CS mode the vehicle utilizes both the engine and electric motor in order to sustain or increase the battery state-of-charge (SOC). An illustration of this architecture is shown in Fig. 1.

1.2 Fuel Economy Evaluation

The vehicle has been evaluated over 4 drive cycles: HWFET, UDDS505, US06 City, and US06 Highway. In order to determine an overall fuel economy, the results of each drive cycle are weighted using a method similar to the Environmental Protection Agency (EPA) 5-cycle test [2]. The utilized method evaluates the vehicle over city and highway driving conditions and enables estimation of the vehicle's 5-cycle performance. Unlike the EPA test, it did not include vehicle evaluation at cold temperatures.

The pre-transmission parallel PHEV operates in both CD and CS modes. In order to include the electric range in the estimated fuel economy, the vehicle's fuel economy has been calculated according to SAE Standard J1711 [3]. This standard weights the vehicle's performance over the CD and CS modes of operation through the use of a utility factor (UF), which is calculated according to the vehicle's all-electric range.

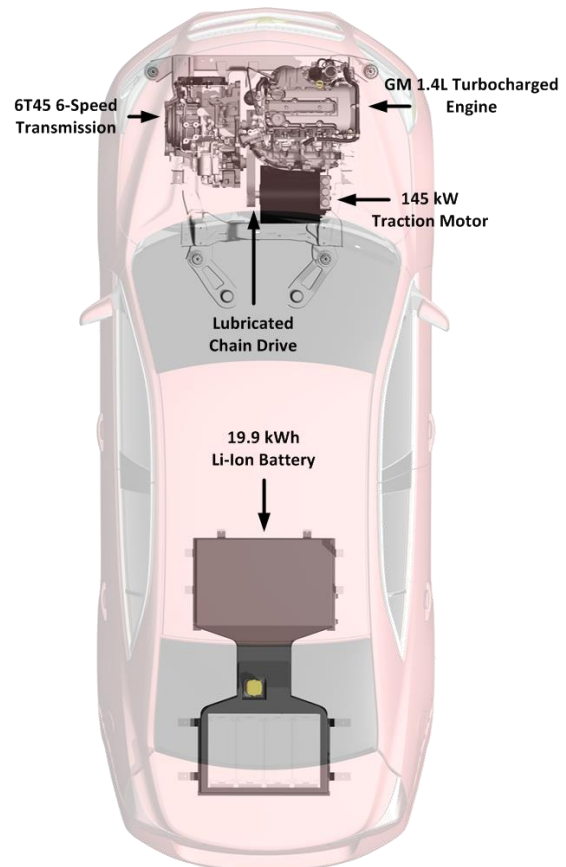

Fig. 1. Pre-transmission parallel PHEV architecture

2 Vehicle Simulation

The development of the supervisory control strategy and the vehicle model utilized in the SIL and HIL simulations has been performed using Matlab Simulink. The use of a common software environment between the vehicle model and control strategy has enabled rapid transitioning between SIL, HIL, and in-vehicle evaluations.

2.1 Component Modelling

In order to obtain simulation results representative of the vehicle, accurate models which replicate component functionality are required. The SIL and HIL vehicle simulations implement these component models through a combination of MSU developed models and dSPACE Automotive Simulation Models (ASM) using Matlab and Simulink. While dSPACE ASM models have been developed for a variety of common automotive systems, only the gasoline engine, transmission, vehicle longitudinal dynamics, and multi-cell battery models have been used in this vehicle simulation [4].

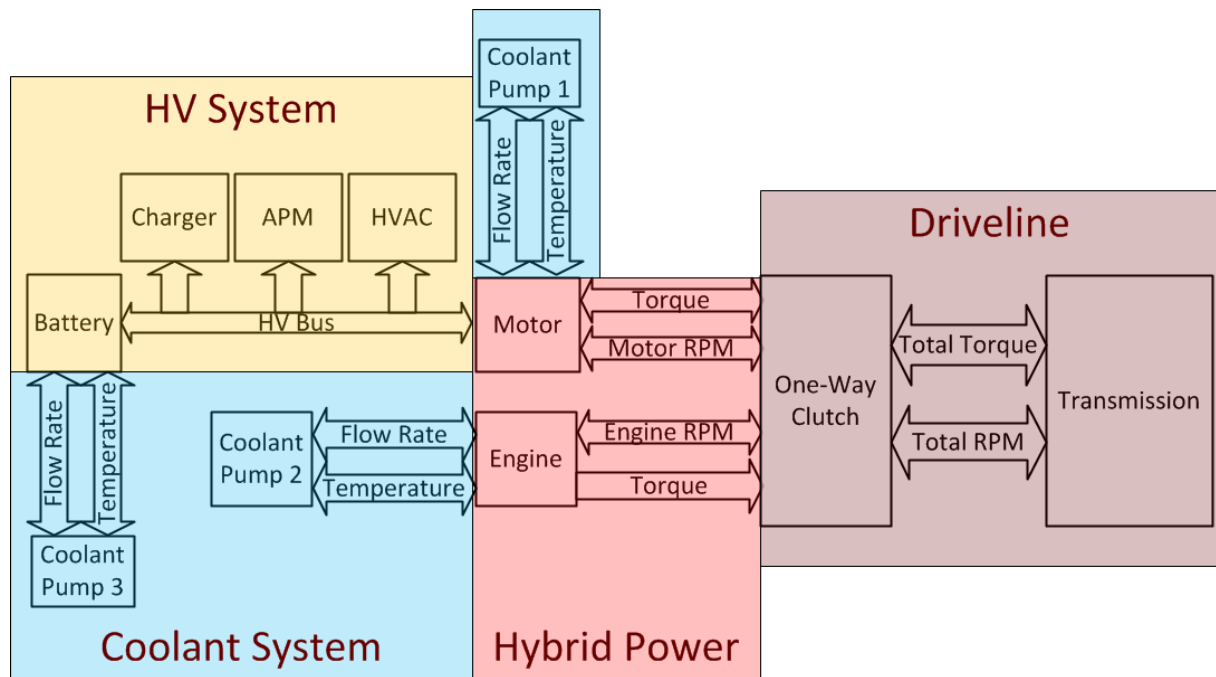

Fig. 2. Overview of vehicle simulation model [5]

Vehicle component models which have been developed at MSU include the electric traction motor, one-way overrunning clutch, battery charger, and auxiliary power module (APM). Since the vehicle's engine is not enabled during CD operation, an APM, or DC/DC converter, is required to sustain the vehicle's low voltage system. An overview of the vehicle simulation model is presented in Fig. 2.

Each of the ASM and MSU simulated components consist of two sub models: a plant model and a software electronic control unit (SoftECU) model. The plant sub-model simulates the physical characteristics of a component. For example, the APM plant sub-model calculates the resulting load on the high-voltage system by estimating the low-voltage system load and applying the APM's power conversion efficiency. The SoftECU simulates the controller which manages the component. The use of a SoftECU enables correct development of the supervisory control algorithms by replicating the internal logic, communication, and input and output (I/O) present on the actual component. Using the APM as an example, its SoftECU receives signals from the vehicle's controller area network (CAN) communication bus and determines whether the appropriate conditions have been met for enabling or disabling the

APM. An example of this is illustrated in Fig. 3 for the APM SoftECU and plant sub-models.

Obviously the overall fidelity of such simulations is dependent upon the accuracy of the data used to develop and parameterize the model. Each of the dSPACE and MSU models has been parameterized using information provided by the manufacturer or the results from bench evaluation of the component. This data is incorporated into the model through lookup tables and state machines to provide a balance between model development time and model fidelity.

2.2 CAN Latency in SIL Simulation

One of the features that has enabled the successful development of the supervisory control strategy and improved the vehicle model is the implementation of CAN latency into SIL simulations. On a HIL system, as on an actual vehicle where CAN hardware is utilized, messages are commonly transmitted at a cyclic rate. The delays experienced by this cyclic transmission rate can have significant effects on control algorithms which are state based or implemented in closed loop control. As a result, algorithms which have been developed in a SIL simulation could fail or become unstable once subject to HIL or in-vehicle evaluation.

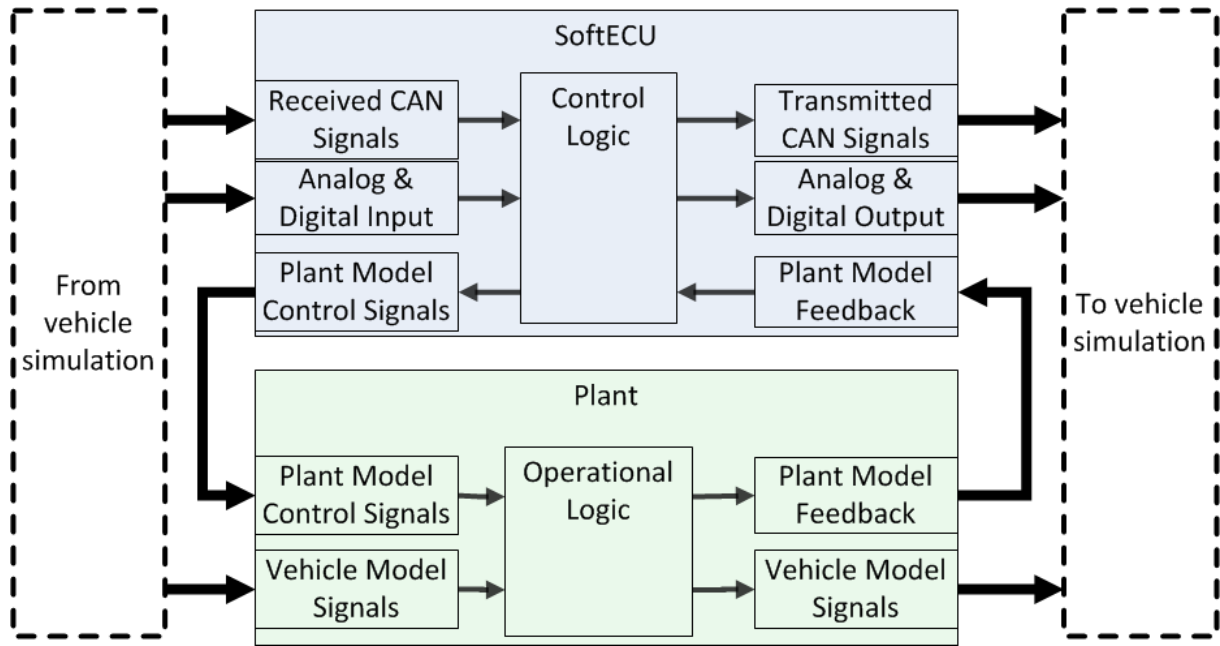

Fig. 3. APM component model overview illustrating the SoftECU and plant sub-models

The developed vehicle model implements CAN message latency into the SIL simulation through the use of sample-and-hold algorithms. These algorithms utilize a resettable timer to replicate the message's cyclic transmission rate. Each time this timer reaches the desired time limit, the CAN message signals are sampled from the vehicle model, passed to the control strategy, and then returned to a hold state. The effectiveness of this method is illustrated in Fig. 4, where the CAN message containing the motor torque request is compared for the SIL and HIL simulations.

3 Supervisory Control Strategy

Integration of the hybrid components into the vehicle requires the use of a supervisory control system to manage the new components and interface them to the vehicle platform. As the vehicle is constructed, rapid development and calibration of the supervisory controller is required in order to implement safety features and reduce the vehicle's fuel economy and emissions. To meet this demand, a supervisory control system consisting of two rapid control prototyping (RCP) controllers has been utilized. Low power digital, non-isolated analog I/O and CAN communication has been implemented using a dSPACE MicroAutoBoxII controller while high power I/O and isolated analog I/O have been achieved using a dSPACE RapidPro controller. The combination of these two RCP

controllers has provided a system with extensive I/O and high computational capability.

The designed vehicle can operate in two primary modes: charge depletion (CD) and charge sustain (CS). In each of these modes of operation, the vehicle performance can vary depending on the level of optimization of their control strategies. Since the main focus of the vehicle's development up to this point of time has been implementation, the supervisory control system utilizes control strategies which provide the required functionality but have not yet been optimized.

The developed CD and CS control strategies utilize a calculated driver torque request in order to determine the appropriate powertrain response. In an effort to maintain drivability similar to a conventional vehicle, a pedal map from a production vehicle has been utilized. This pedal map monitors the driver pedal position and the transmission input speed to calculate the driver requested torque. In order to accommodate the increased torque capability of the hybrid powertrain, the output torque of this pedal map has been normalized. This normalization enables the maximum powertrain torque to be defined by the supervisory control strategy for different vehicle modes. For example, the maximum powertrain torque could be reduced during a limp-home mode or increased during a performance mode. The utilized pedal map is illustrated in Fig. 5.

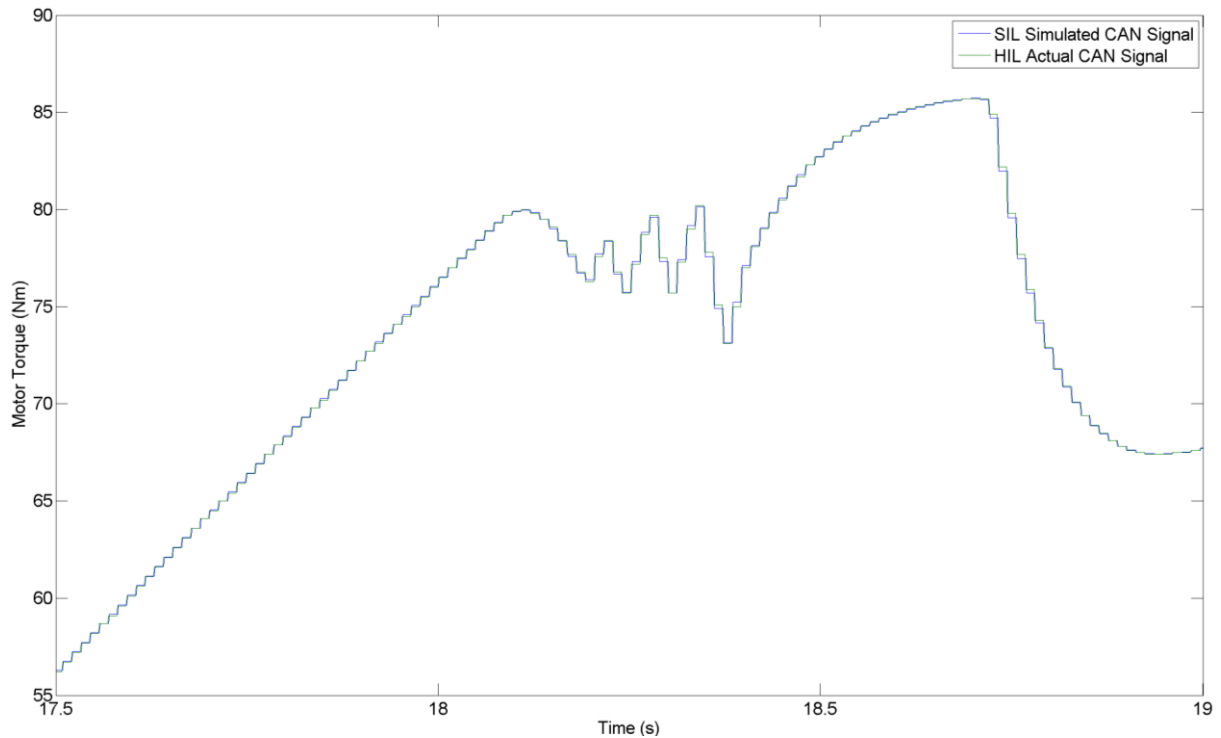

Fig. 4. Motor torque request received using CAN communication during SIL and HIL simulations

3.1 Charge Depletion Strategy

Since the electric motor is the only tractive power source active during CD mode, the driver's requested torque is commanded directly to the motor. One unique requirement of the CD strategy is the simulation of engine idle. During CD operation it is necessary to simulate an engine idle because the torque converter acts as both a torque coupling and a hydraulic pump. If the input speed to the torque converter is not maintained, a loss of hydraulic pressure will occur and result in unexpected transmission behaviour. In order to avoid this, the CD control strategy utilizes a PID controller to maintain a reference speed during idle conditions.

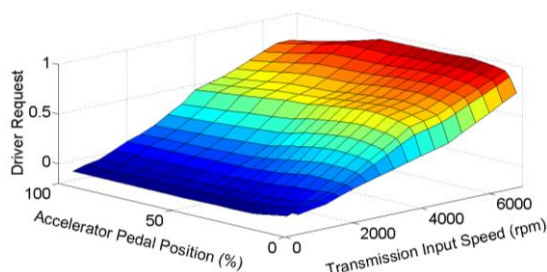

Fig. 5. Normalized driver pedal map

3.2 Charge Sustaining Strategy

The CS control strategy is much more complex than the CD strategy since the engine and motor torque must be combined. The CS strategy must increase the battery SOC, operate within the charge and discharge limits of the battery, and manage the engine and motor torque to meet the driver's torque request. In order to accomplish this complex controls task, a three input, single output fuzzy logic controller has been utilized. The fuzzy logic controller monitors the driver torque request, battery SOC, and battery charge and discharge limits and calculates a normalized motor torque request. The resulting computational surface created for this fuzzy logic controller is illustrated in Fig. 6 for the driver torque request versus the battery SOC.

Figure 6 illustrates several important features implemented by the fuzzy logic controller. At high SOC the normalized motor torque is limited to positive values while the opposite is true at low SOC. In addition to this, the motor torque is blended between regeneration and propulsion when the driver request is approximately 200 Nm. This enables the vehicle to meet the high accelerations required as the driver's requested torque increases.

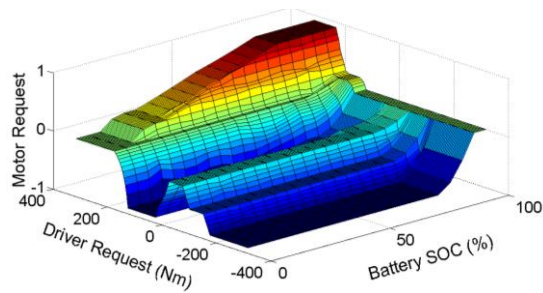

Fig. 6. Fuzzy logic controller output

4 Results

4.1 SIL Simulation Results

The initial vehicle evaluations were performed using CD and CS modes in SIL simulations. The individual drive cycle results for these evaluations are presented in Table 1.

Table 1 – SIL Simulation Drive Cycle Results

Drive Cycle	CD Energy Consumption (Wh/km)	CS Fuel Consumption (L _{E85} /100km)
HWFET	188.0	7.20
UDDS 505	238.1	8.73
US06 City	433.1	10.94
US06 Highway	218.3	7.47

The two highway drive cycles resulted in lower CD energy consumption and CS fuel consumption when compared with the two city drive cycles. The increased energy and fuel consumption of the US06 drive cycles illustrates their increased aggressiveness and power demands when compared with the UDDS505 and HWFET drive cycles. The drive cycle results of Table 1 have been combined and weighted according to SAE Standard J1711 to compute the overall vehicle fuel consumption. These results are presented in Table 2 for the vehicle's E85 and gasoline equivalent (GE) fuel consumption.

Table 2 – SIL Simulation Combined Results

CD Range (km)	Utility Factor	UF Fuel Consumption (L _{E85} /100km)	UF Fuel Consumption (L _{GE} /100km)
67.9	0.667	5.43	3.82

The combined results of Table 2 estimate the vehicle's electric range to be 67.9 km, or 42.2 miles. The resulting utility factor according to SAE standard J1711 is 0.667 and weights the vehicle's combined CD and CS performance. The SIL simulation overall vehicle fuel economy when using E85 is 43.4 mpg, while the gasoline equivalent fuel economy is 61.5 mpg.

4.2 HIL Simulation Results

In order to validate the SIL simulation results, the vehicle was also evaluated using a HIL simulator. The HIL evaluation results for both CD and CS modes of operation are presented in Table 3.

Table 3 – HIL Simulation Drive Cycle Results

Drive Cycle	CD Energy Consumption (Wh/km)	CS Fuel Consumption (L/100km)
HWFET	187.0	7.20
UDDS 505	238.9	9.33
US06 City	422.7	11.83
US06 Highway	220.4	7.43

The HIL evaluation results were similar to those previously obtained in the SIL simulations. The most significant difference between the HIL and SIL simulations occurred for the US06 City drive cycle with the HIL result being approximately 2.5% higher than the SIL. The combined drive cycle results for the HIL simulation are presented in Table 4.

Table 4 – HIL Simulation Combined Results

CD Range (km)	Utility Factor	UF Fuel Consumption (L/100km)	UF Fuel Consumption (L _{ge} /100km)
68.0	0.668	5.51	3.88

Similar to the SIL results in Table 2, the HIL results of Table 4 estimated the vehicle's electric range to be 68 km, or 42.3 miles. The HIL utility factor weighted fuel economy using E85 was 42.7 mpg, while the gasoline equivalent fuel economy was 60.6 mpg.

5 Conclusion

SIL and HIL simulation has been utilized to estimate the pre-transmission parallel PHEV's fuel economy. In order to ensure accurate results, high

fidelity component models were developed and implemented in the vehicle simulation model. The accuracy of the SIL evaluations was further improved through the simulation of CAN message latency.

The vehicle's fuel economy was estimated using four drive cycles: HWFET, UDDS, US06 City, and US06 Highway. The CD and CS results of each drive cycle has been combined and weighted according to SAE Standard J1711 in order to estimate the overall vehicle fuel consumption. The overall fuel economy results for the SIL and HIL simulations were similar, with an approximate 1.5% difference between their gasoline equivalent fuel economy.

References

- [1] *About EcoCAR 2* [Online], Available: <http://www.ecocar2.org/about-ecocar2>
- [2] *Fuel Economy Labeling of Motor Vehicle Revisions to Improve Calculation of Fuel Economy Estimates*, EPA 420-R-06-017, 2006
- [3] *Recommended Practice for Measuring the Exhaust Emissions and Fuel Economy of Hybrid Electric Vehicles*, SAE J1711, Mar 1999.
- [4] K. Patil *et al.*, "Hybrid Vehicle Model Development using ASM-ASMESim-Simscape Co-Simulation for Real-Time HIL Applications," SAE 2012-01-0932
- [5] J. Moore and G. M. Molen, "Simulation and Hardware-in-the-Loop Evaluation of a GM Malibu," in *Vehicle Power and Propulsion Conf.*, 2012, pp. 1155-1159.

Authors

G. Marshall Molen graduated from Texas Tech University with the BS, MS, and Ph.D. in electrical engineering. He has been employed in industry at The Aerospace Corporation and ESCO Manufacturing Company. His academic career includes serving as associate dean at Old Dominion University, chairman of the Department of Electrical Engineering at Tennessee Technological University, and ten years as department head at Mississippi State University. He is the Ergon Distinguished Professor at MSU and the chief automotive engineer with the Center for Advanced Vehicular Systems at Mississippi State University. He was the faculty advisor for the MSU Challenge X and EcoCar competitions sponsored by General Motors and the Department of Energy, and is

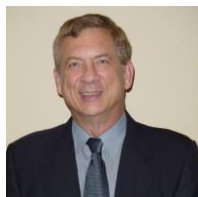

now the faculty advisor for EcoCar 2 that is the follow-on competition.

Jonathan D. Moore graduated from Hendrix College with a BS in chemical physics in 2010 and is currently working on his MS in electrical engineering at Mississippi State University. He was the team leader for vehicle electrical integration on the MSU EcoCar team and is the controls and simulation team leader for the MSU EcoCar 2 team. His current activities include



vehicle simulation, fault testing, and validation using software-in-the-loop and hardware-in-the-loop as well as supervisory control strategy development on rapid controller prototyping platforms.